



Company: Lamont Doherty Earth Observatory

Well: Expedition 351, Site U1438D

Field: IBM Arc Origins

Rig: JOIDES Resolution Ocean: Pacific

Hostile Natural Gamma Sonde (HNGS)  
Spectroscopy Log

Rig: JOIDES Resolution  
Field: IBM Arc Origins  
Location: Latitude: N 27.383518\*  
Well: Expedition 351, Site U1438D  
Company: Lamont Doherty Earth Observatory

LOCATION	Latitude: N 27.383518*	Elev.: K.B. -4711.00 m
	Longitude: E 134.31837*	G.L. 0.00 m
		D.F. -4711.00 m
	Permanent Datum: Sea Floor	Elev.: 0.00 m
	Log Measured From: Sea Floor	0.00 m above Perm. Datum
	Drilling Measured From: Sea Floor	
API Serial No.		
	N 27.383518	E 134.31837

Logging Date	19-Jun-2014
Run Number	1
Depth Driller	897.8 m
Schlumberger Depth	307 m
Bottom Log Interval	307 m
Top Log Interval	0 m
Casing Driller Size @ Depth	5.500 in @ 95 m
Casing Schlumberger	94 m
Bit Size	9.875 in
Type Fluid In Hole	Seawater/Sepiolite/Barite
MUD Density	1.31809 g/cm3
MUD Viscosity	
MUD Fluid Loss	PH
MUD Source Of Sample	N/A
RM @ Measured Temperature	@ @
RMF @ Measured Temperature	@ @
RMC @ Measured Temperature	@ @
Source RMF	RMC N/A N/A
RM @ MRT	RMF @ MRT @ 14 @ 14 @ @
Maximum Recorded Temperatures	14 degC
Circulation Stopped	Time 18-Jun-2014 23:00
Logger On Bottom	Time 19-Jun-2014 7:25
Unit Number	Location 627314 Houston
Recorded By	K. Swain
Witnessed By	L. Drab

	Run 1	Run 2	Run 3
Logging Date			
Run Number			
Depth Driller			
Schlumberger Depth			
Bottom Log Interval			
Top Log Interval			
Casing Driller Size @ Depth		@	
Casing Schlumberger			
Bit Size			
Type Fluid In Hole			
MUD Density			
MUD Viscosity			
MUD Fluid Loss			
MUD Source Of Sample			
RM @ Measured Temperature		@	
RMF @ Measured Temperature		@	
RMC @ Measured Temperature		@	
Source RMF			
RMC			
RM @ MRT		@	@
RMF @ MRT			
Maximum Recorded Temperatures			
Circulation Stopped			
Time			
Logger On Bottom			
Time			
Unit Number			
Location			
Recorded By			
Witnessed By			

**DISCLAIMER**  
 THE USE OF AND RELIANCE UPON THIS RECORDED-DATA BY THE HEREIN NAMED COMPANY (AND ANY OF ITS AFFILIATES, PARTNERS, REPRESENTATIVES, AGENTS, CONSULTANTS AND EMPLOYEES) IS SUBJECT TO THE TERMS AND CONDITIONS AGREED UPON BETWEEN SCHLUMBERGER AND THE COMPANY, INCLUDING: (a) RESTRICTIONS ON USE OF THE RECORDED-DATA; (b) DISCLAIMERS AND WAIVERS OF WARRANTIES AND REPRESENTATIONS REGARDING COMPANY'S USE OF AND RELIANCE UPON THE RECORDED-DATA; AND (c) CUSTOMER'S FULL AND SOLE RESPONSIBILITY FOR ANY INFERENCE DRAWN OR DECISION MADE IN CONNECTION WITH THE USE OF THIS RECORDED-DATA.

**OTHER SERVICES1**  
 OS1: HLDS/APS/HNGS  
 OS2: HRLA  
 OS3: MSS  
 OS4:  
 OS5:

**OTHER SERVICES2**  
 OS1:  
 OS2:  
 OS3:  
 OS4:  
 OS5:

**REMARKS: RUN NUMBER 1**  
 Hole drilled with RCB coring bit and bottom hole assembly (BHA). 9 7/8 " BS  
 Coring concluded approximately 24 hours prior to logging.  
 Drill pipe set at a depth of 95mbsf with bit dropped at TD.  
 Downlog run with corrections computed using bit size; uplogs corrected for actual hole size.  
 Lower part of toolstring (MSS and HRLA) centralized using modified MCD inline centralizers.  
 Upper part of toolstring (HLDS, APS, HNGS) eccentered using HLDS caliper and bowspring, as per toolsketch.  
 APS minitron remained off during downlog to avoid GR interference / formation activation.  
 Fluid type was barite+seawater gel mud, barite corrections applied.  
 Depth originally recorded from drill floor; played back with sea floor as reference zero.  
 All logs presented in measured depth below sea floor (MDBSF).  
 Maximum observed temperature on the HRLA temperature was 13.5degC.  
 Tools bridged before actual Driller TD at 307m below sea floor.  
 Rig lowered pipe after main logging attempt but 2nd logging attempt did not get significantly further so no more data was acquired and remaining logging cancelled for this hole D.

**REMARKS: RUN NUMBER 2**

**RUN 1**

SERVICE ORDER #: \_\_\_\_\_  
 PROGRAM VERSION: 19C0-187  
 FLUID LEVEL: \_\_\_\_\_

LOGGED INTERVAL	START	STOP

**RUN 2**

SERVICE ORDER #: \_\_\_\_\_  
 PROGRAM VERSION: \_\_\_\_\_  
 FLUID LEVEL: \_\_\_\_\_

LOGGED INTERVAL	START	STOP

## EQUIPMENT DESCRIPTION





**RUN 1**

**SURFACE EQUIPMENT**

SFT-281 1  
 SFT-178 1  
 GSR-U 616008  
 WITM (EDTS)-A 1

**RUN 2**

**DOWNHOLE EQUIPMENT**

LEH-QT	MDSB_EDTC		38.54	39.87
AH-369	Mud Tempe		37.48	38.98
	CTEM		36.91	
EDTC-B	Gamma Ray		38.54	38.54
EDTH-B 8303	EFTB DIAG		36.56	35.86
	TelStatus		35.86	
EDTC-B 8317	EDTCB Ele		35.86	35.86
UNGG DA	Upper 1		35.86	35.86

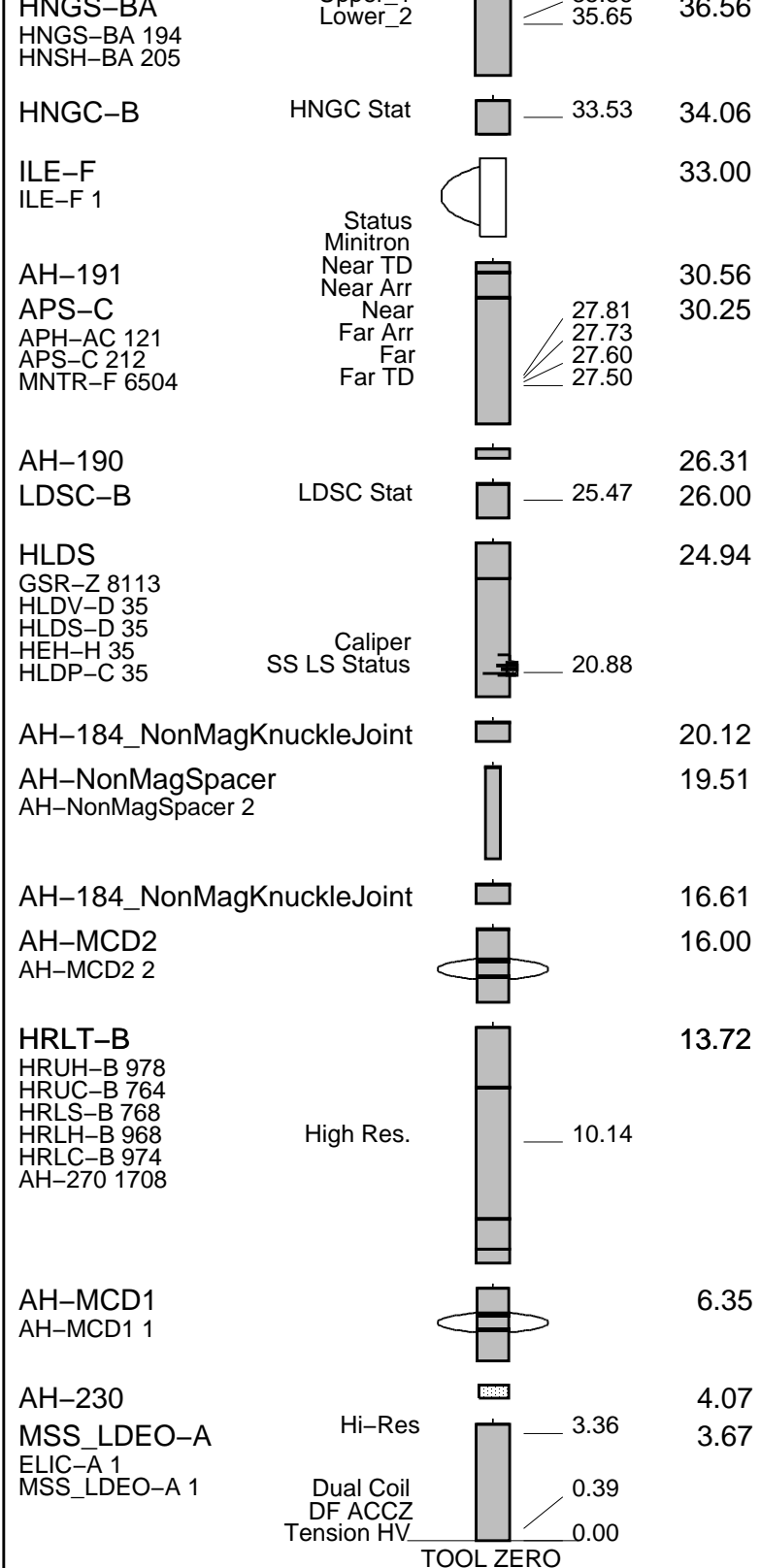
MAXIMUM STRING DIAMETER 3.75 IN  
 MEASUREMENTS RELATIVE TO TOOL ZERO  
 ALL LENGTHS IN METERS

Production String	(in)	(M)	Well Schematic	(M)	(in)	Casing String
	OD	ID		MD	MD	

Kelly Bushing Elevation  
Derrick Floor Elevation

Mean Sea Level

-471

-471

-4700

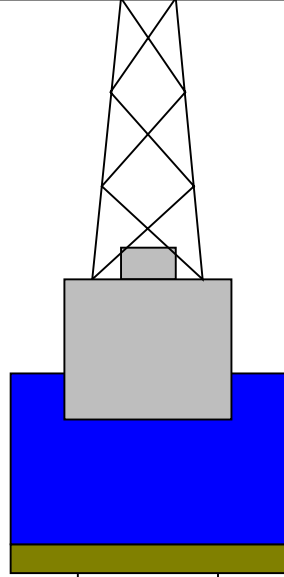

4.1

Sea Floor

0

4.1

Drill Pipe

95

Open Hole

9.875

Total Depth

897.8



### Input DLIS Files

DEFAULT MSS\_LDEO\_HRLA\_LDL\_018LUP FN:26 PRODUCER 19-Jun-2014 00:41 5029.2 M 4689.2 M

### Output DLIS Files

DEFAULT MSS\_LDEO\_HRLA\_LDL\_033PUP FN:46 PRODUCER 20-Jun-2014 18:21 312.4 M -27.7 M

### OP System Version: 19C0-187

MSS_LDEO-A	19C0-187	HRLT-B	19C0-187
HLDS	19C0-187	LDSC-B	19C0-187
APS-C	19C0-187	HNGC-B	19C0-187
HNGS-BA	19C0-187	EDTC-B	SKK-5169-EDTCB

### PIP SUMMARY

Time Mark Every 60 S

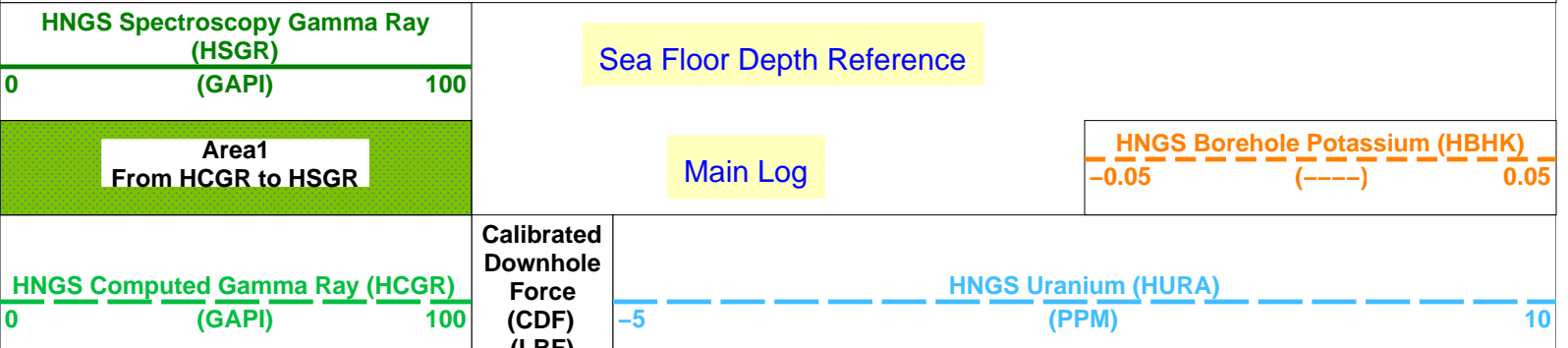

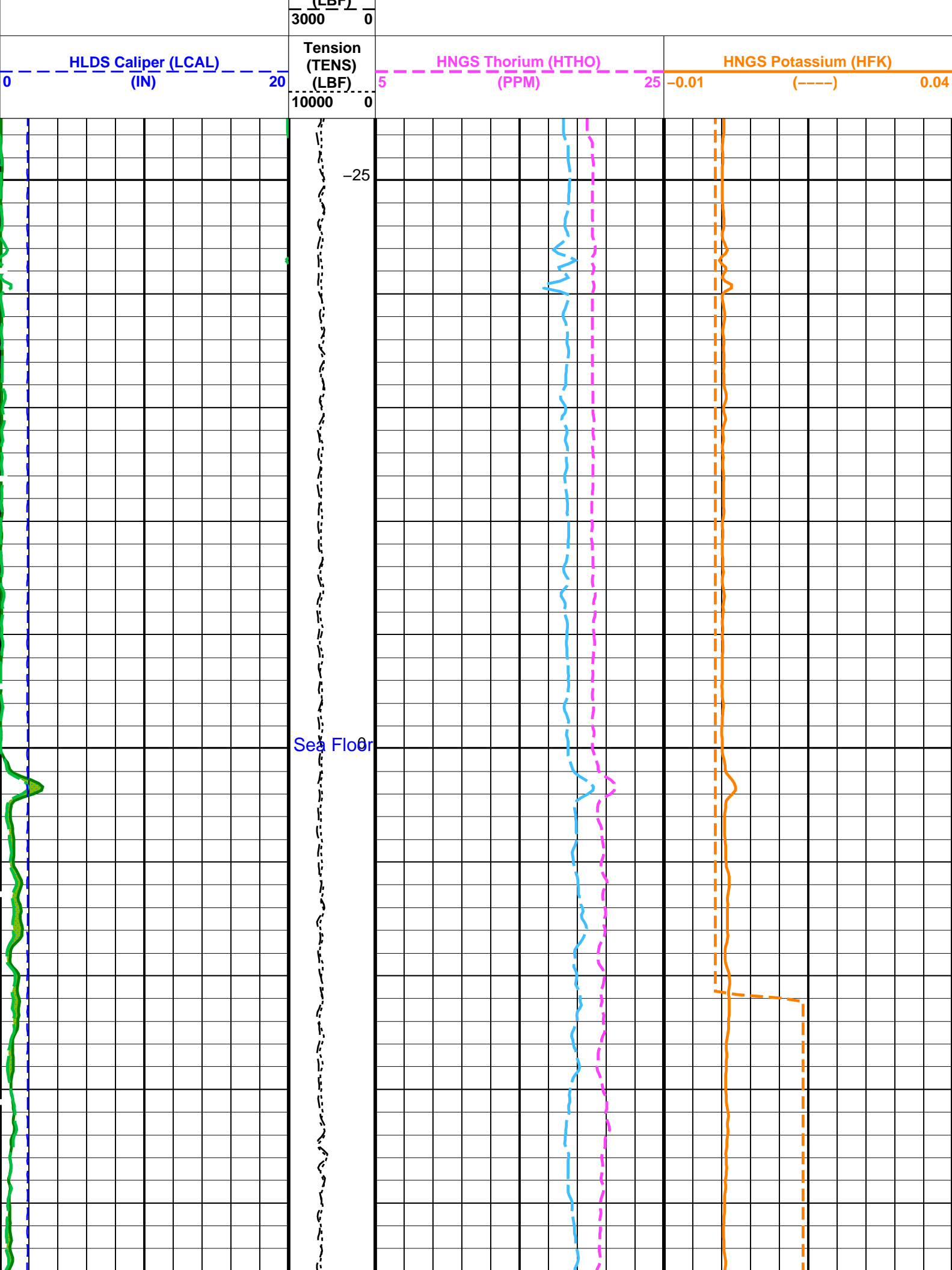

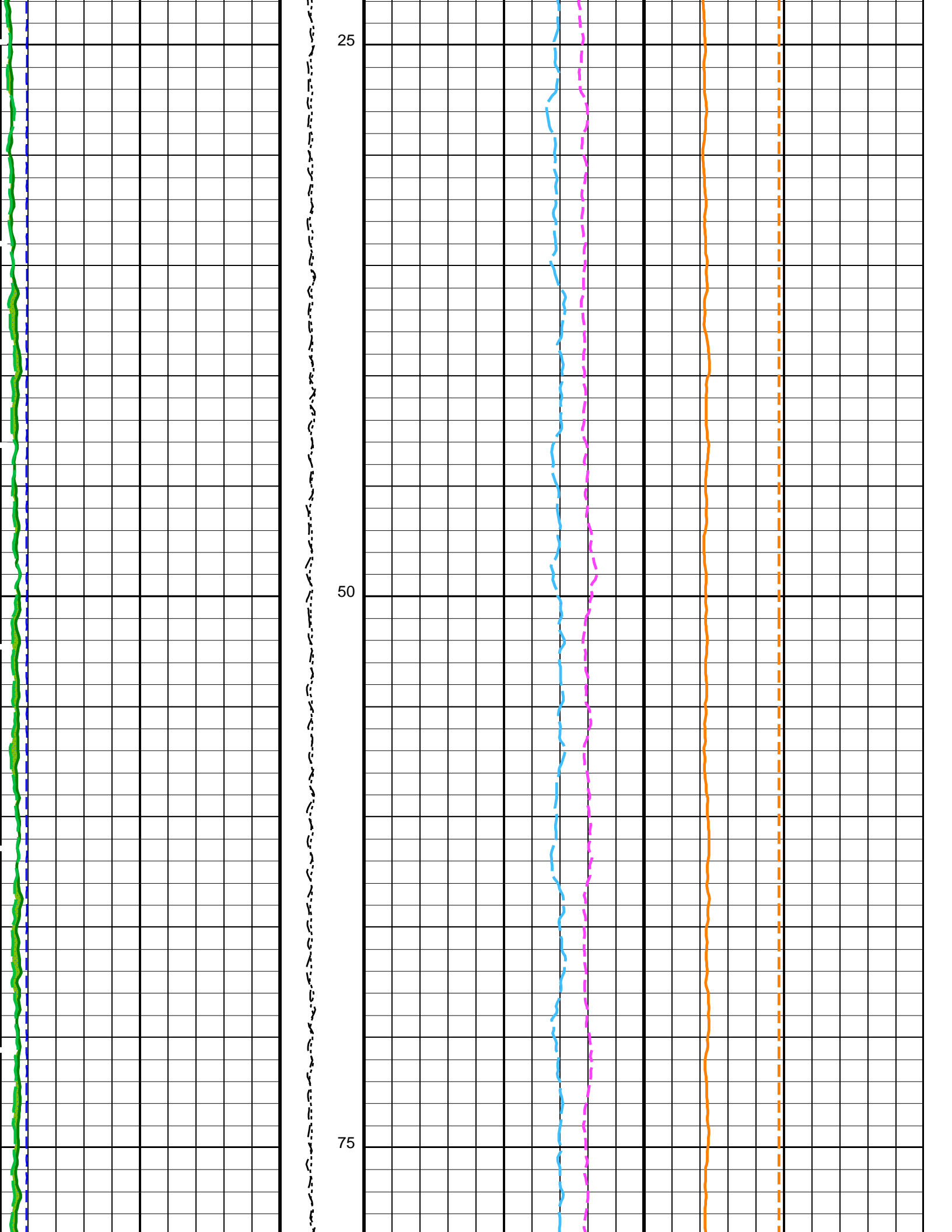

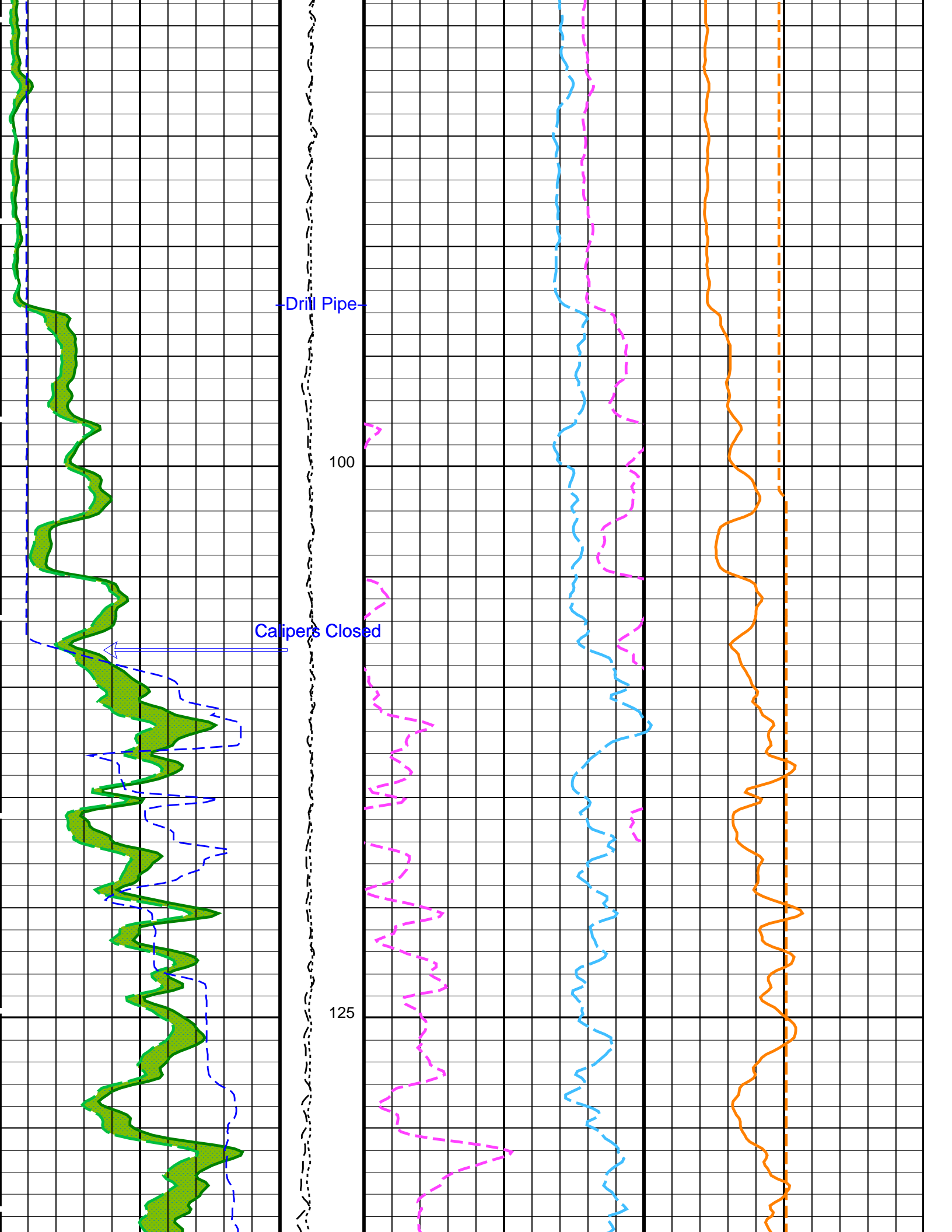



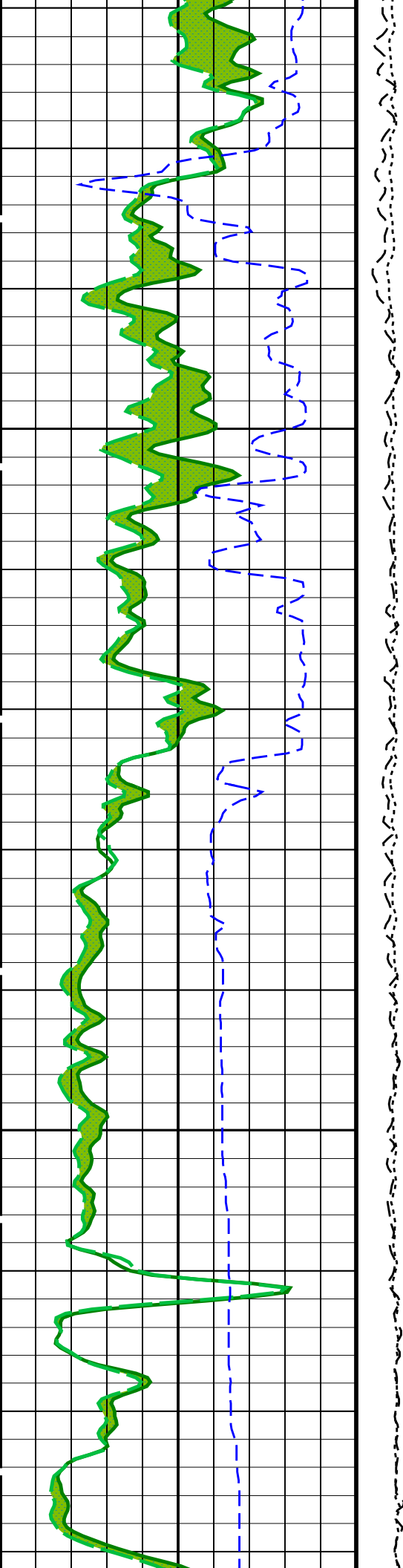

150

175

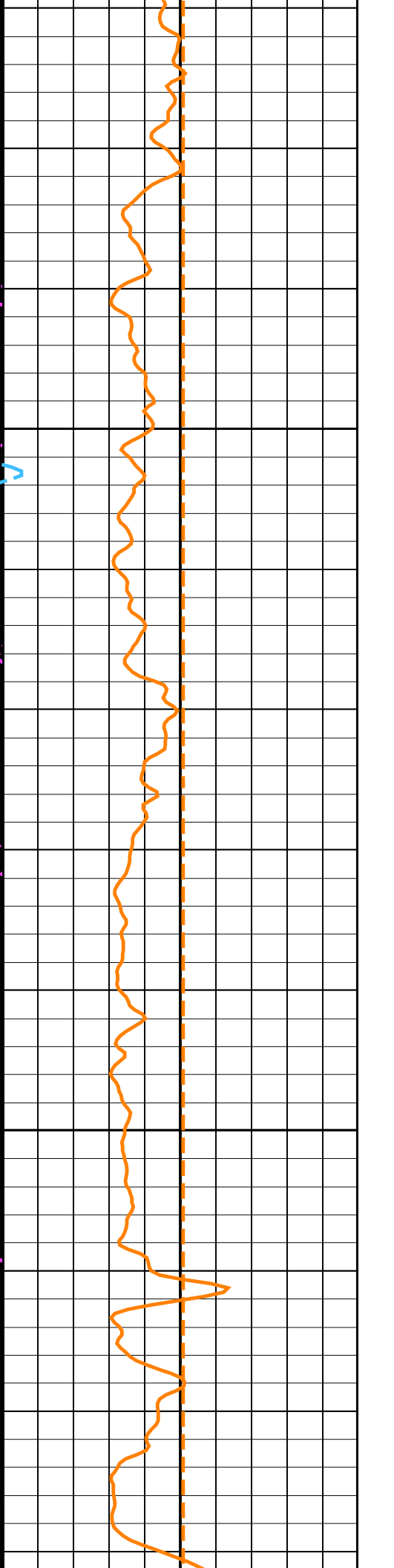
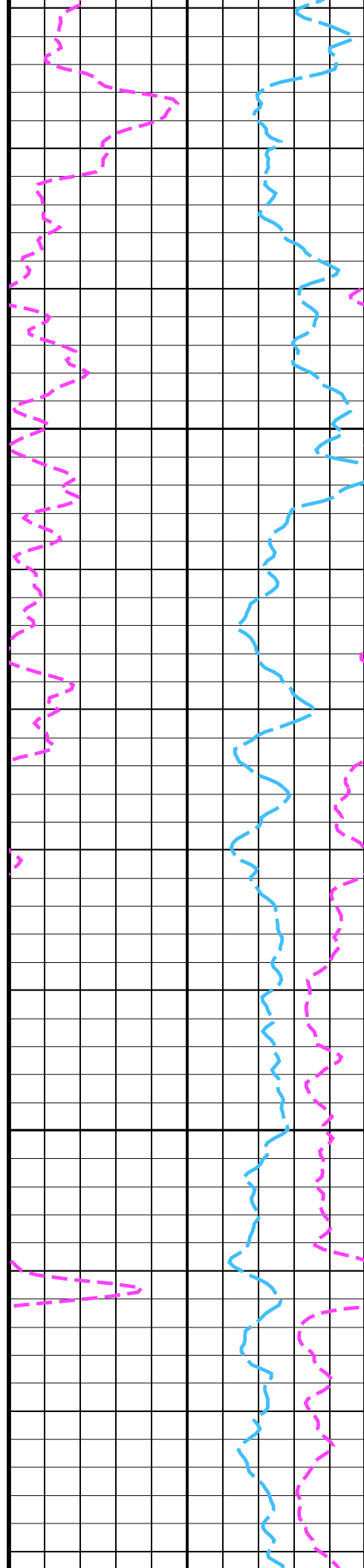

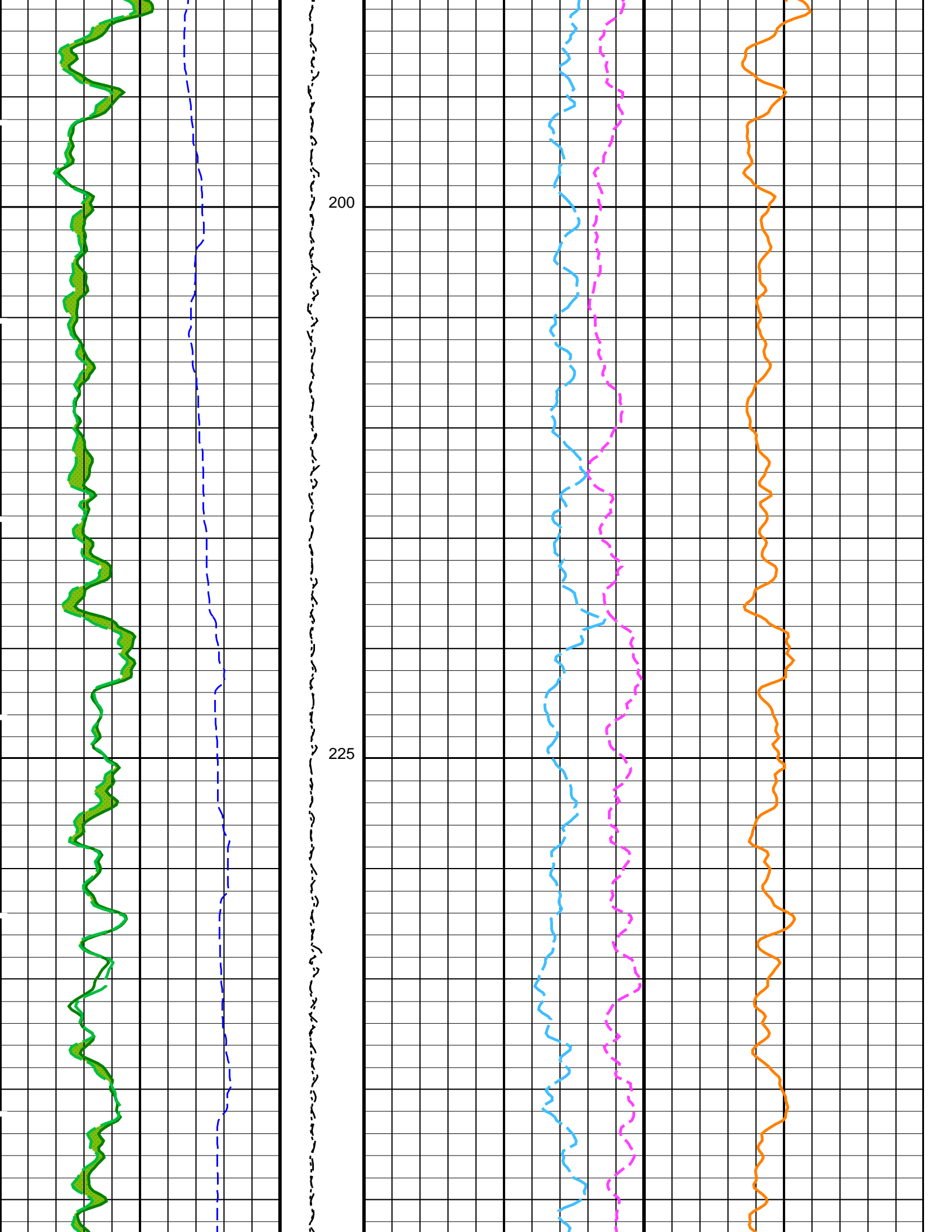

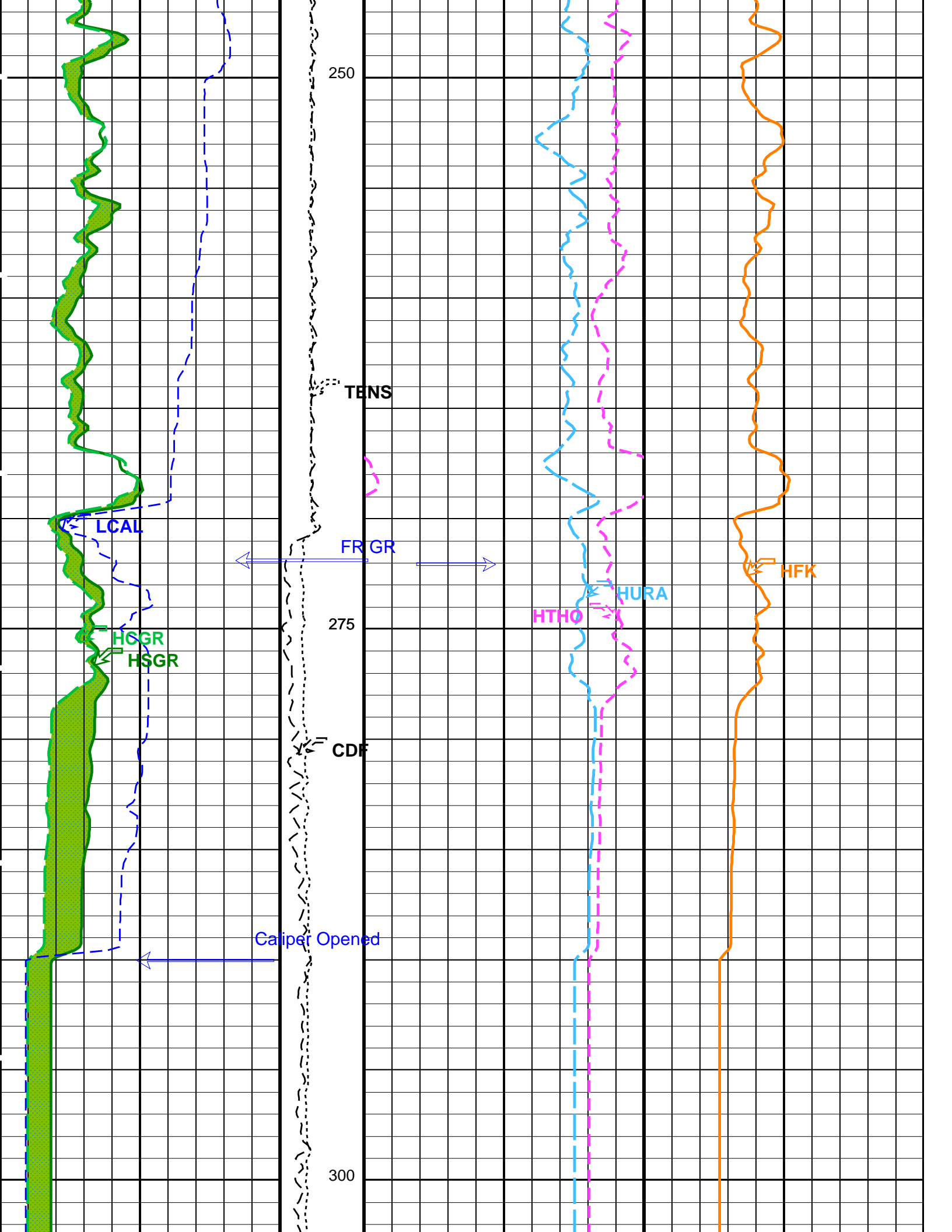

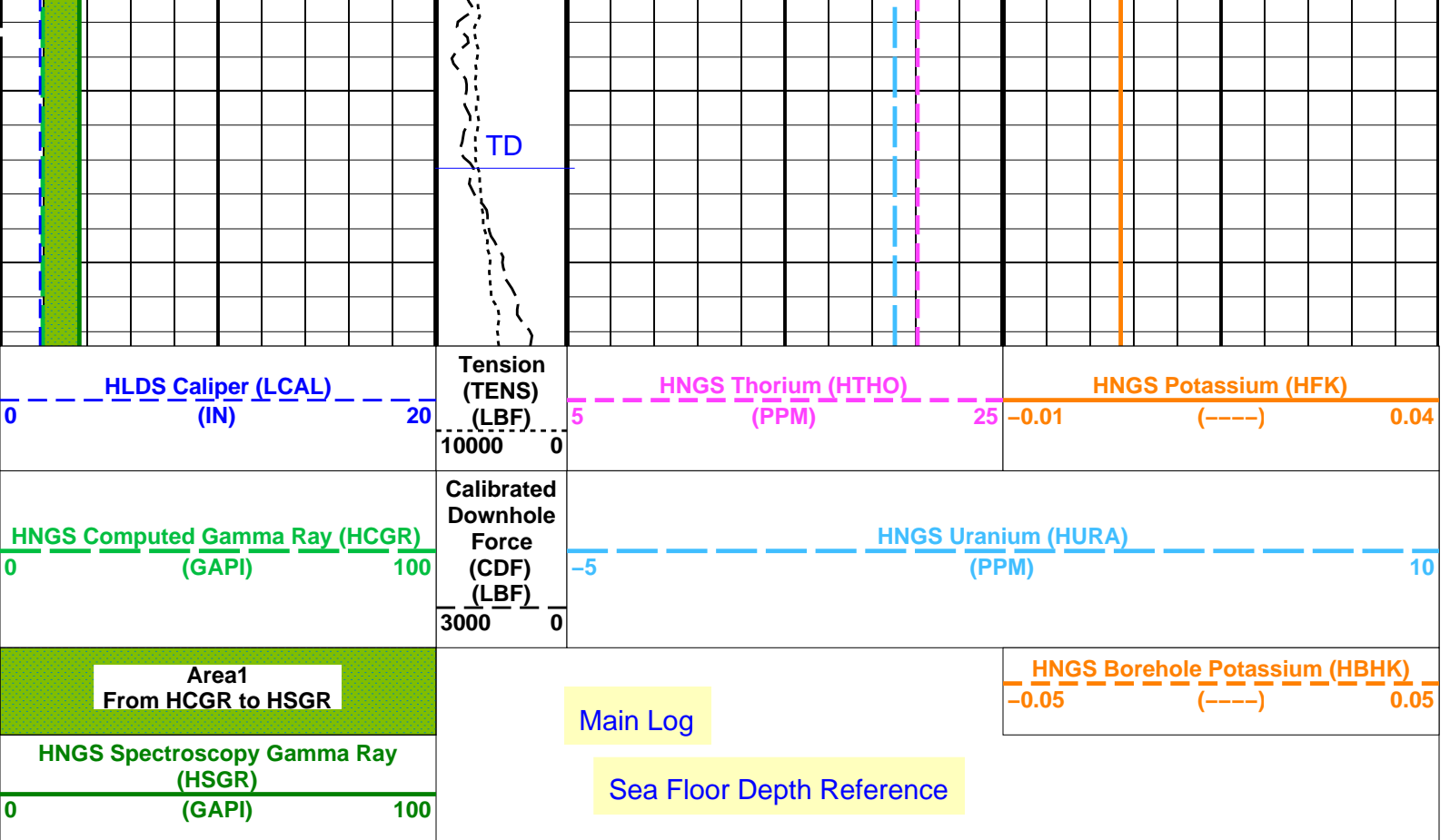

PIP SUMMARY

Time Mark Every 60 S

Parameters

DLIS Name	Description	Value
BHS	HRLT-B: High Resolution Laterolog Array - B	
Borehole Status		OPEN
GCSE	Generalized Caliper Selection	LCAL
BHS	APS-C: Accelerator-Porosity Tool	
Borehole Status		OPEN
GCSE	Generalized Caliper Selection	LCAL
BAR1	HNGS-BA: Hostile Natural Gamma Ray Sonde	
HNGS Detector 1 Barite Constant		1
BAR2	HNGS Detector 2 Barite Constant	1
BHK	HNGS Borehole Potassium Correction Concentration	0
BHS	Borehole Status	OPEN
CSD1	Inner Casing Outer Diameter	0 IN
CSD2	Outer Casing Outer Diameter	0 IN
CSW1	Inner Casing Weight	0 LB/F
CSW2	Outer Casing Weight	0 LB/F
DBCC	HNGS Barite Constant Correction Flag	NONE
GCSE	Generalized Caliper Selection	LCAL
H1P	HNGS Detector 1 Allow/Disallow In Processing	ALLOW
H2P	HNGS Detector 2 Allow/Disallow In Processing	ALLOW
HABK	HNGS Borehole Potassium Running Average	-0.000822794
HALF	HNGS Alpha Filter Length	60 IN
HCRB	HNGS Apply Borehole Potassium Correction	NONE
HMWM	Mud Weighting Material	BARI
HNPE	HNGS Processing Enable	YES
S1BI	HNGS Detector 1 Calibration Bismuth Count Rate	1.3 CPS
S2BI	HNGS Detector 2 Calibration Bismuth Count Rate	1.3 CPS
SGRC	HNGS Standard Gamma-Ray Correction Flag	YES
TPOS	Tool Position	CENT
VBA1	HNGS Detector 1 Variable Barite Factor Running Average	-4.27844
VBA2	HNGS Detector 2 Variable Barite Factor Running Average	1.8508
BHS	EDTC-B: Enhanced DTS Cartridge	
Borehole Status		OPEN
GCSE	Generalized Caliper Selection	LCAL
BS	System and Miscellaneous	
Bit Size		9.875 IN
DO	Depth Offset for Playback	-4717.0 M
PP	Playback Processing	NORMAL

# OP System Version: 19C0-187

MSS_LDEO-A	19C0-187	HRLT-B	19C0-187
HLDS	19C0-187	LDSC-B	19C0-187
APS-C	19C0-187	HNGC-B	19C0-187
HNGS-BA	19C0-187	EDTC-B	SKK-5169-EDTCB

## Input DLIS Files

DEFAULT	MSS_LDEO_HRLA_LDL_018LUP	FN:26	PRODUCER	19-Jun-2014 00:41	5029.2 M	4689.2 M
---------	--------------------------	-------	----------	-------------------	----------	----------

## Output DLIS Files

DEFAULT	MSS_LDEO_HRLA_LDL_033PUP	FN:46	PRODUCER	20-Jun-2014 18:21		
---------	--------------------------	-------	----------	-------------------	--	--

## Input DLIS Files

DEFAULT	Flip_MSS_LDEO_HRLA_029PUP		PRODUCER	20-Jun-2014 18:03	274.2 M	-93.7 M
---------	---------------------------	--	----------	-------------------	---------	---------

## Output DLIS Files

DEFAULT	MSS_LDEO_HRLA_LDL_030PUP	FN:43	PRODUCER	20-Jun-2014 18:06	274.2 M	-93.7 M
---------	--------------------------	-------	----------	-------------------	---------	---------

# OP System Version: 19C0-187

MSS_LDEO-A	19C0-187	HRLT-B	19C0-187
HLDS	19C0-187	LDSC-B	19C0-187
APS-C	19C0-187	HNGC-B	19C0-187
HNGS-BA	19C0-187	EDTC-B	SKK-5169-EDTCB

### PIP SUMMARY

Time Mark Every 60 S

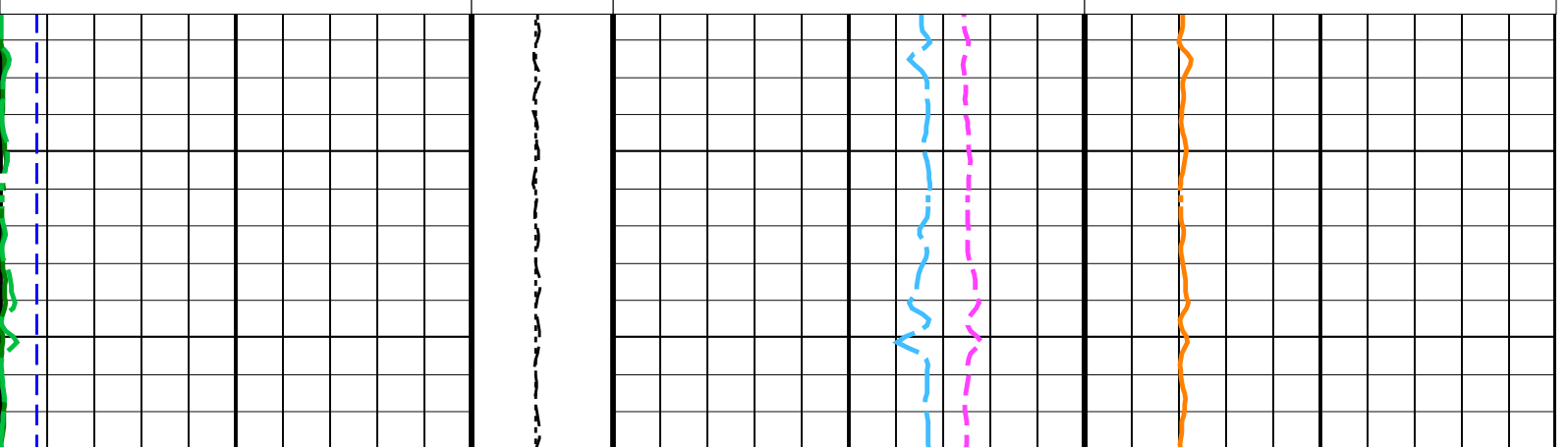
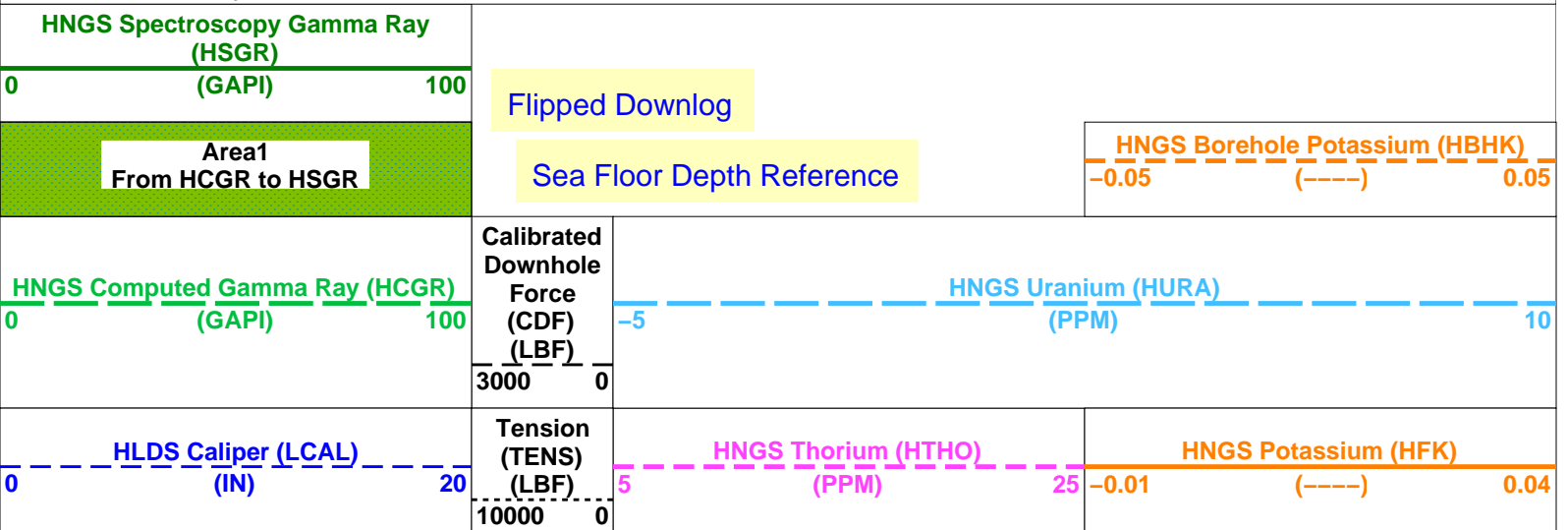

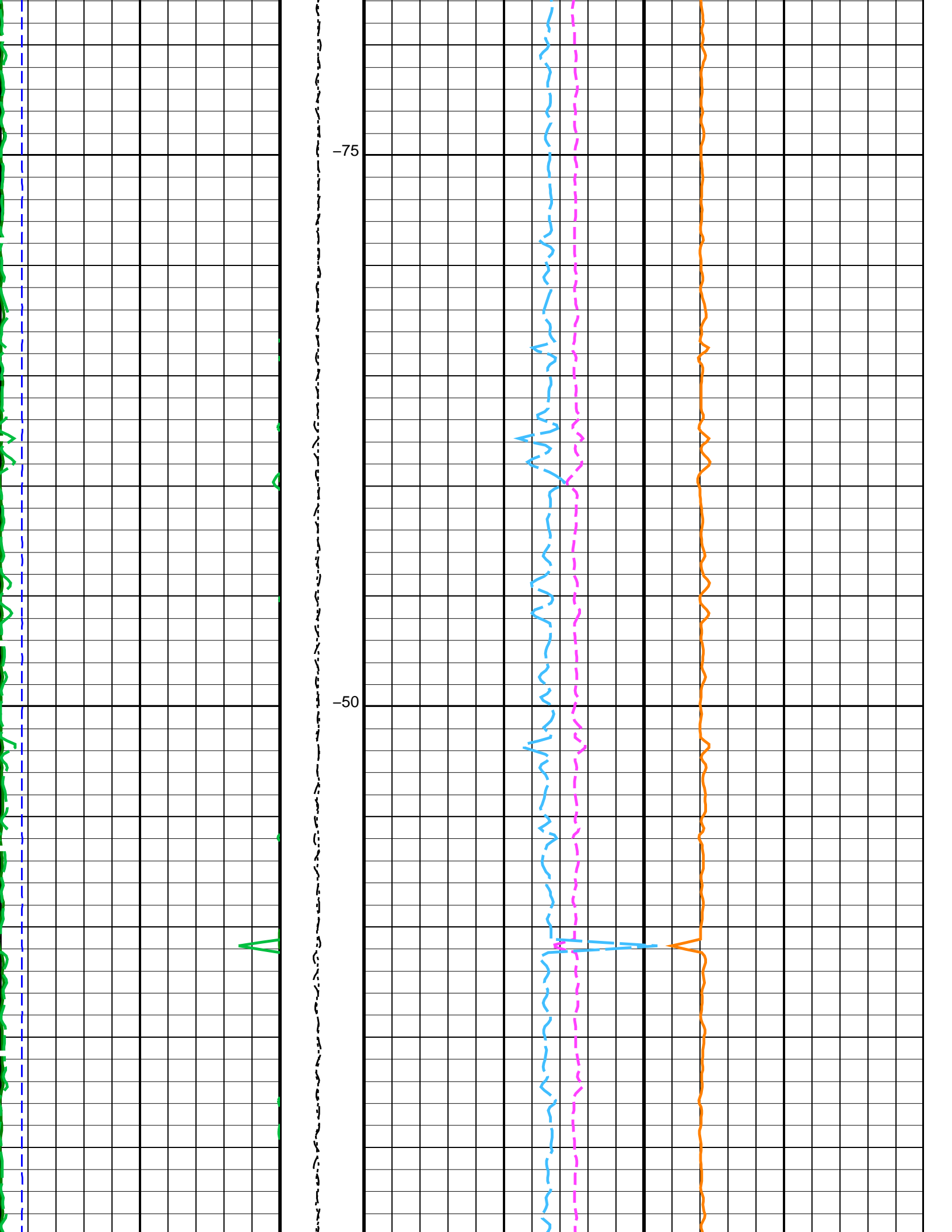

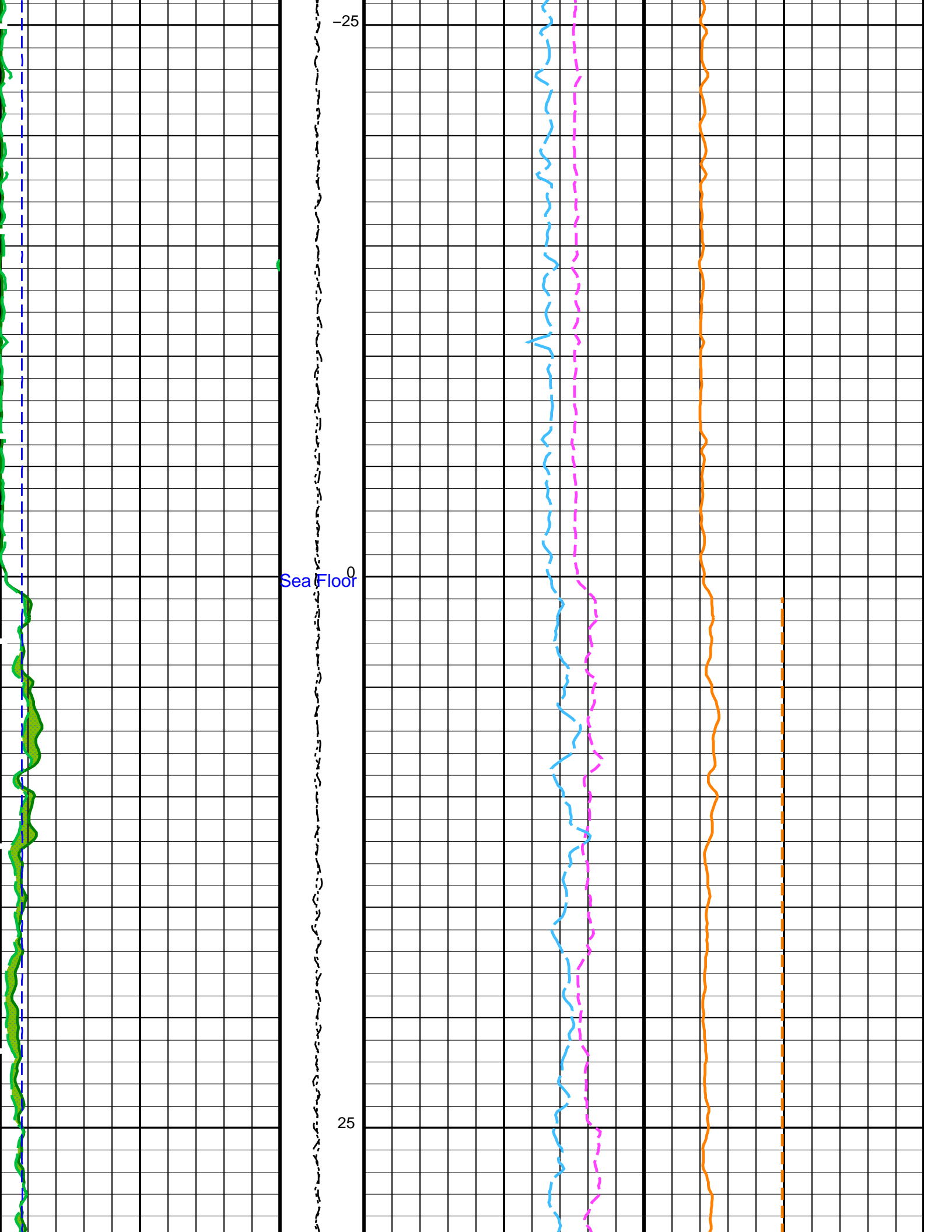

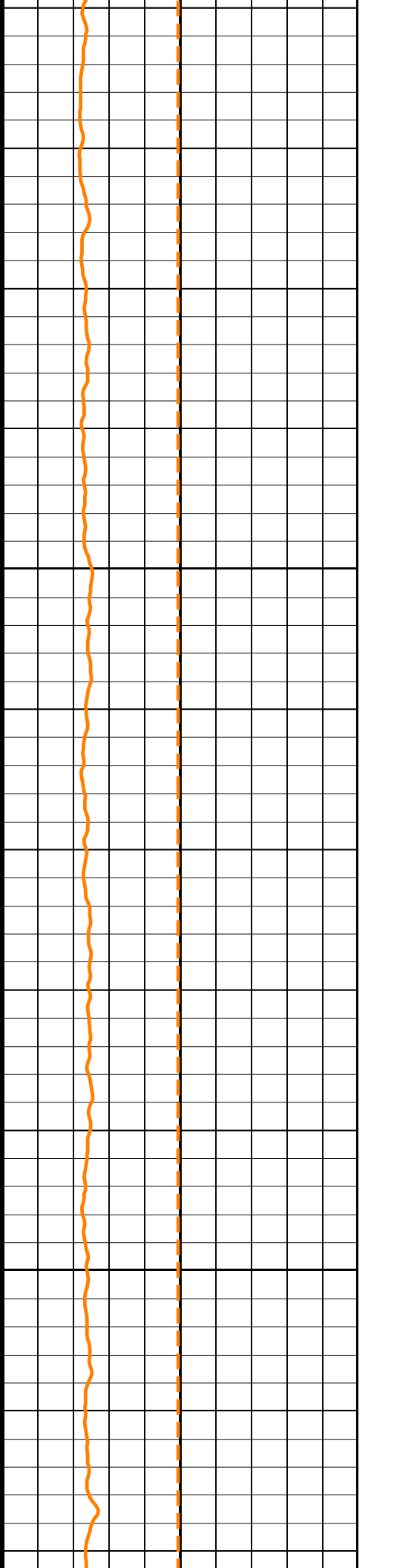
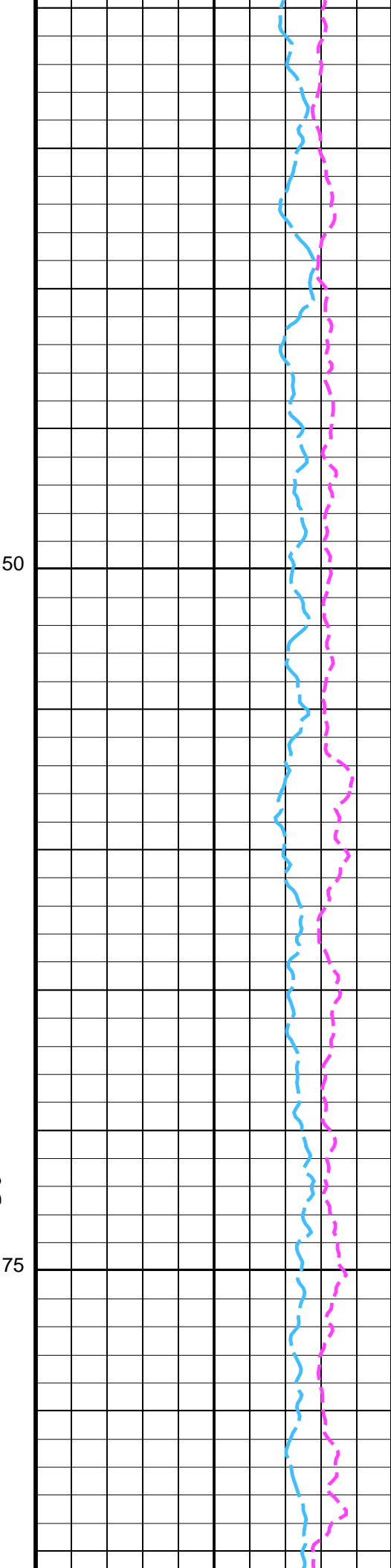
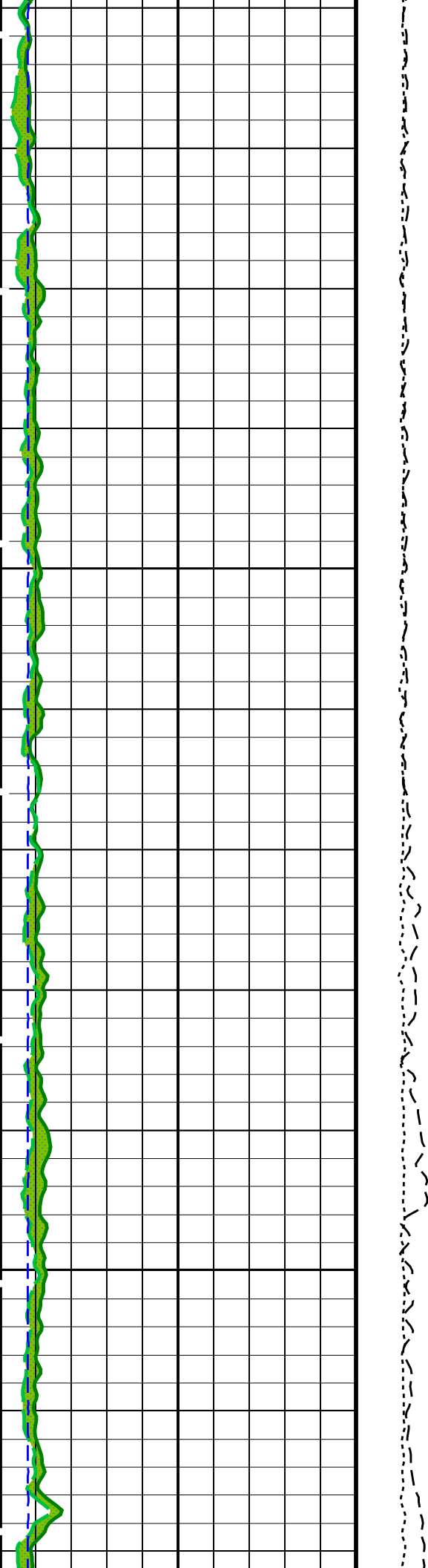



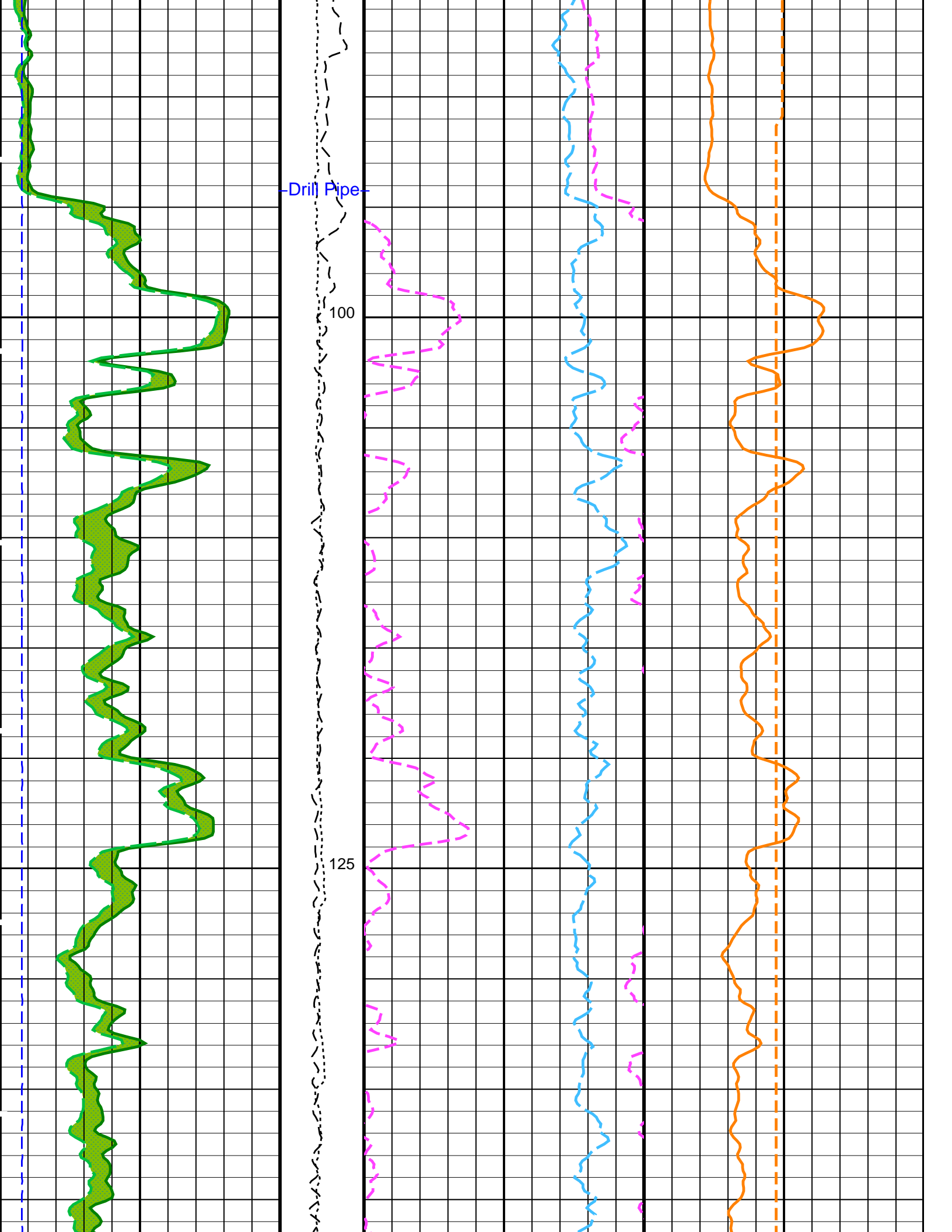

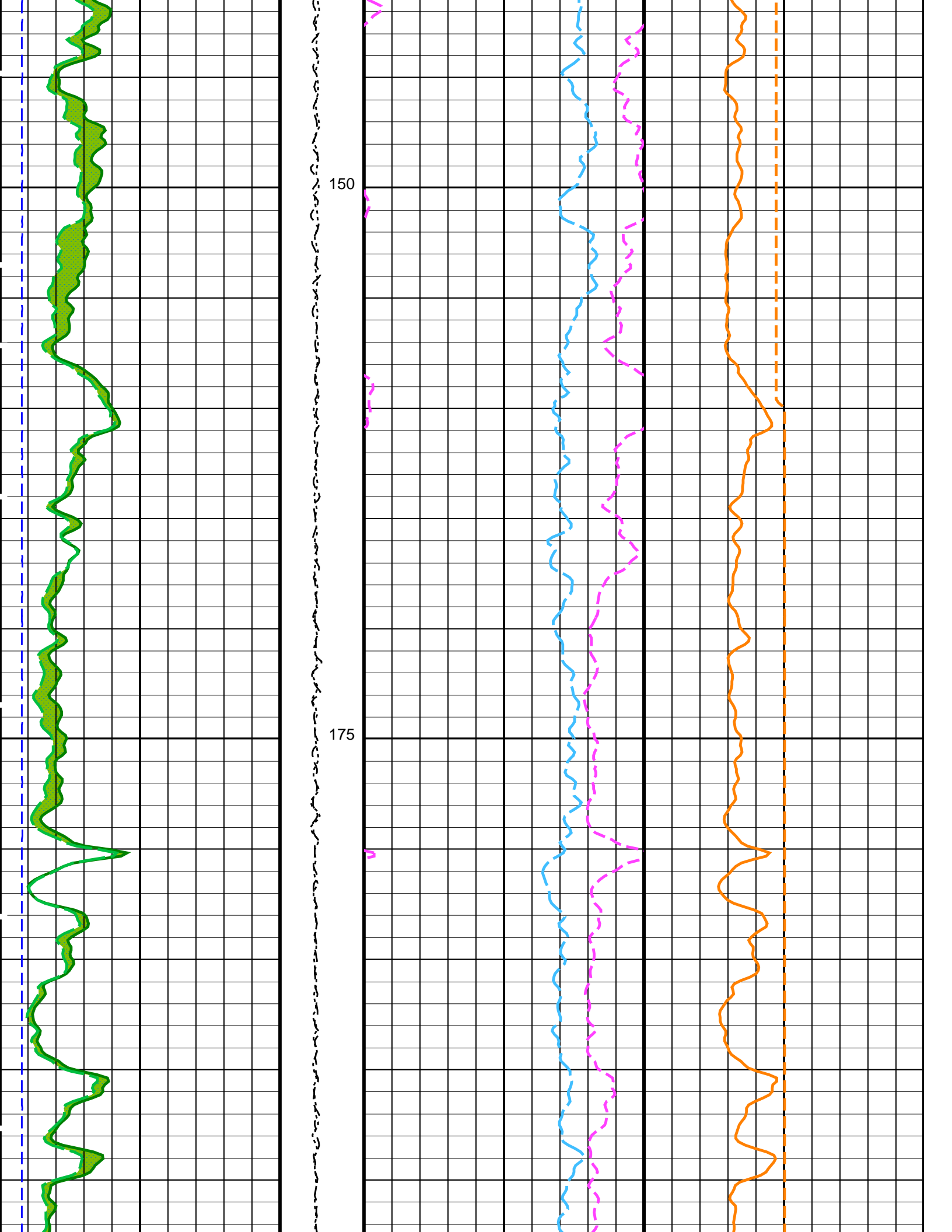

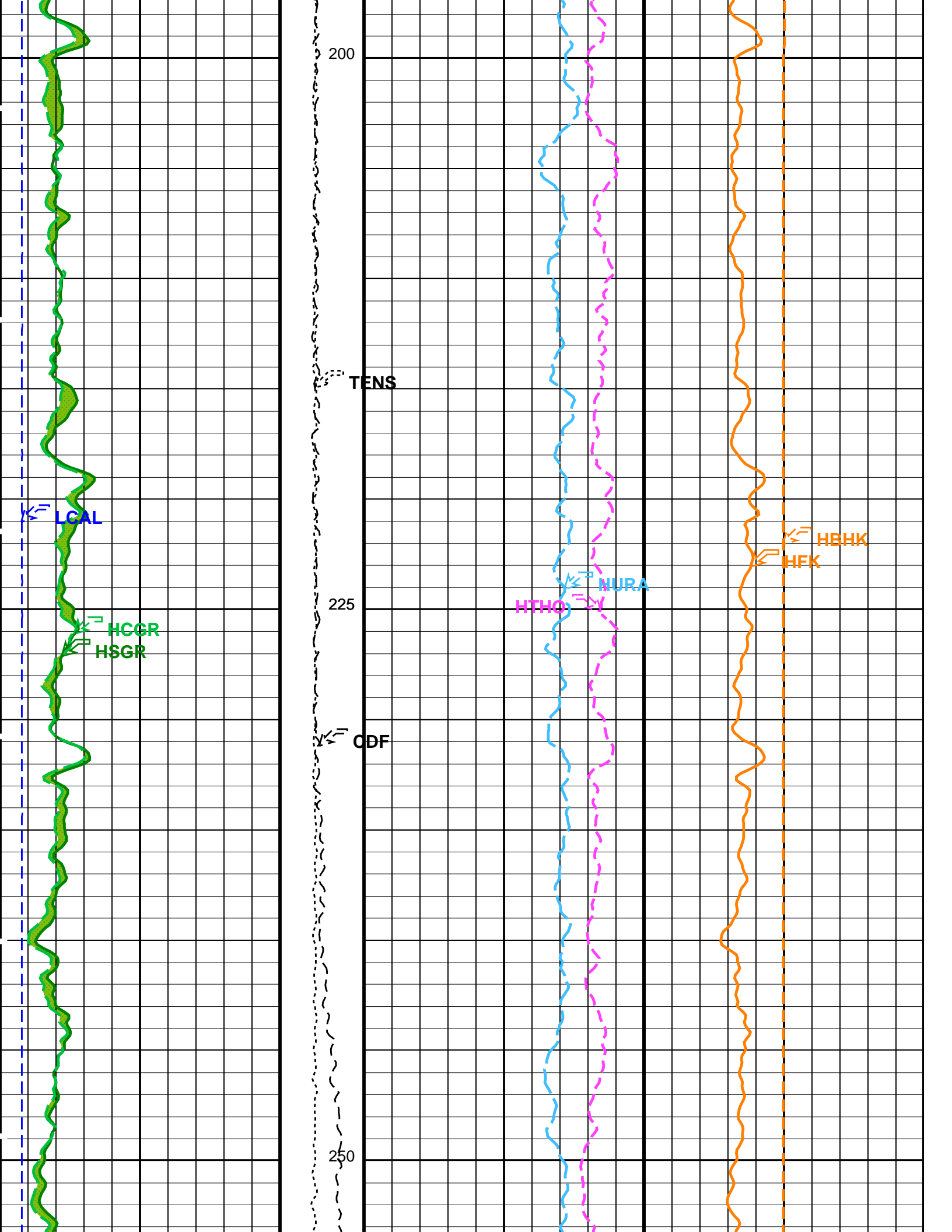

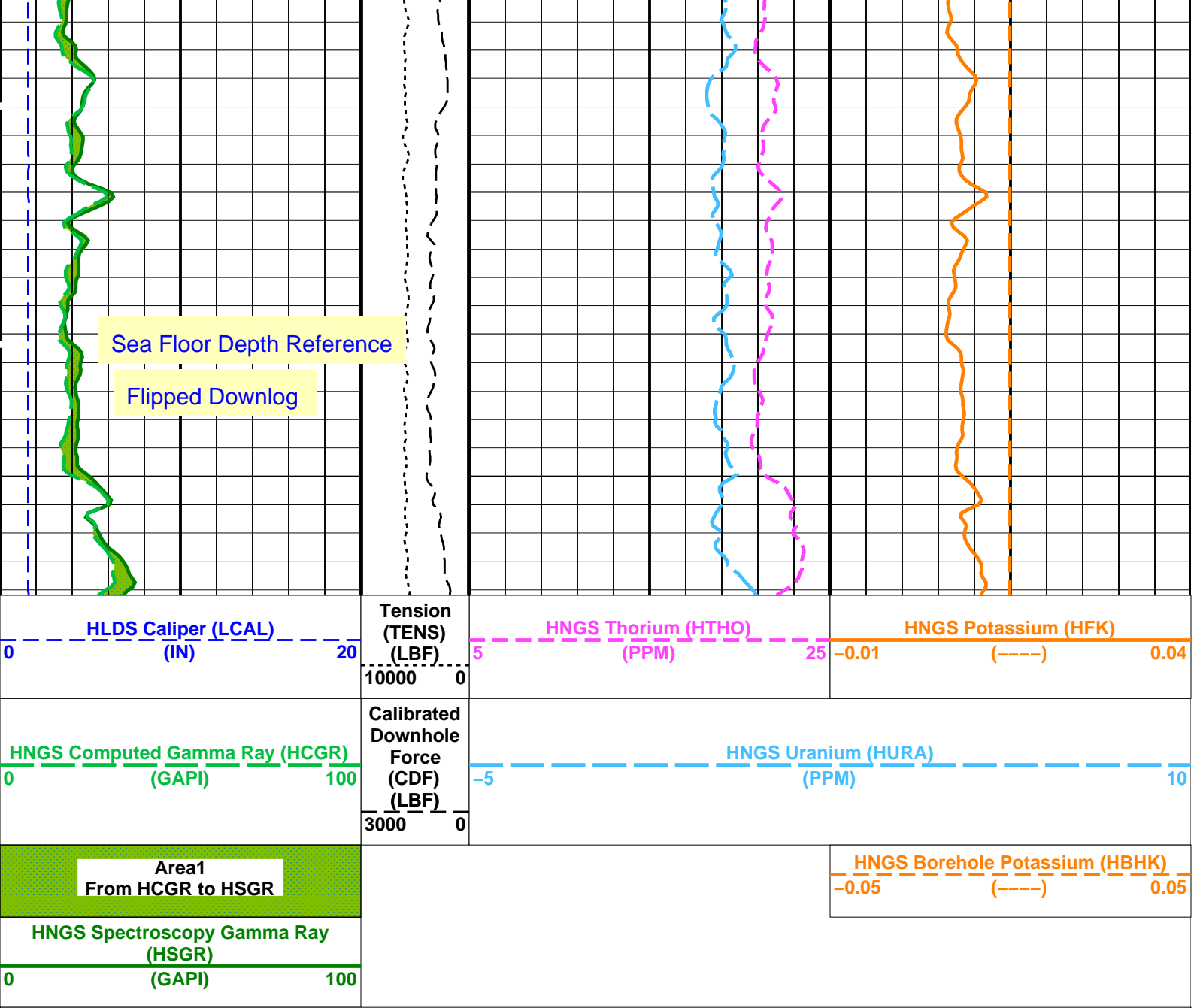

Time Mark Every 60 S

### Parameters

DLIS Name	Description	Value
HRLT-B: High Resolution Laterolog Array - B		
BHS	Borehole Status	OPEN
GCSE	Generalized Caliper Selection	BS
APS-C: Accelerator-Porosity Tool		
BHS	Borehole Status	OPEN
GCSE	Generalized Caliper Selection	BS
HNGS-BA: Hostile Natural Gamma Ray Sonde		
BAR1	HNGS Detector 1 Barite Constant	1
BAR2	HNGS Detector 2 Barite Constant	1
BHK	HNGS Borehole Potassium Correction Concentration	0
BHS	Borehole Status	OPEN
CSD1	Inner Casing Outer Diameter	0 IN
CSD2	Outer Casing Outer Diameter	0 IN
CSW1	Inner Casing Weight	0 LB/F
CSW2	Outer Casing Weight	0 LB/F
DBCC	HNGS Barite Constant Correction Flag	NONE
GCSE	Generalized Caliper Selection	BS
H1P	HNGS Detector 1 Allow/Disallow In Processing	ALLOW
H2P	HNGS Detector 2 Allow/Disallow In Processing	ALLOW
HABK	HNGS Borehole Potassium Running Average	-0.000483385
HALF	HNGS Alpha Filter Length	60 IN
HCRB	HNGS Apply Borehole Potassium Correction	NONE

HMWM	Mud Weighting Material	BARI	
HNPE	HNGS Processing Enable	YES	
S1BI	HNGS Detector 1 Calibration Bismuth Count Rate	1.3	CPS
S2BI	HNGS Detector 2 Calibration Bismuth Count Rate	1.3	CPS
SGRC	HNGS Standard Gamma-Ray Correction Flag	YES	
TPOS	Tool Position	CENT	
VBA1	HNGS Detector 1 Variable Barite Factor Running Average	1.11288	
VBA2	HNGS Detector 2 Variable Barite Factor Running Average	1.20228	
<b>EDTC-B: Enhanced DTS Cartridge</b>			
BHS	Borehole Status	OPEN	
GCSE	Generalized Caliper Selection	BS	
<b>System and Miscellaneous</b>			
BS	Bit Size	9.875	IN
DO	Depth Offset for Playback	0.0	M
PP	Playback Processing	NORMAL	

Format: HNGSYields    Vertical Scale: 1:200    Graphics File Created: 20-Jun-2014 18:06

### OP System Version: 19C0-187

MSS_LDEO-A	19C0-187	HRLT-B	19C0-187
HLDS	19C0-187	LDSC-B	19C0-187
APS-C	19C0-187	HNGC-B	19C0-187
HNGS-BA	19C0-187	EDTC-B	SKK-5169-EDTCB

### Input DLIS Files

DEFAULT	Flip_MSS_LDEO_HRLA_029PUP	PRODUCER	20-Jun-2014 18:03	274.2 M	-93.7 M
---------	---------------------------	----------	-------------------	---------	---------

### Output DLIS Files

DEFAULT	MSS_LDEO_HRLA_LDL_030PUP	FN:43	PRODUCER	20-Jun-2014 18:06
---------	--------------------------	-------	----------	-------------------

### Calibration and Check Summary

Measurement	Nominal	Master	Before	After	Change	Limit	Units
<b>High Resolution Laterolog Array - B Wellsite Calibration - HRLT M01</b>							
Before: 19-Jun-2014 0:19    After: 19-Jun-2014 1:30							
HRLT M0-M1 Voltage Plus - 0	0	N/A	-319.3	-319.0	0.2621	9.681	UV
HRLT M0-M1 Voltage Plus - 1	0	N/A	-333.4	-334.3	-0.8940	9.681	UV
HRLT M0-M1 Voltage Plus - 2	0	N/A	-335.0	-334.9	0.01013	9.681	UV
HRLT M0-M1 Voltage Plus - 3	0	N/A	-338.4	-338.4	-0.05707	9.681	UV
HRLT M0-M1 Voltage Plus - 4	0	N/A	-326.6	-326.4	0.1615	9.681	UV
HRLT M0-M1 Voltage Plus - 5	0	N/A	-322.6	-322.5	0.1267	9.681	UV
HRLT M0-M1 Voltage Plus - 6	0	N/A	323.8	325.1	1.280	9.681	UV
HRLT M0-M1 Voltage Plus - 7	0	N/A	-322.7	-322.7	0	9.681	UV
<b>High Resolution Laterolog Array - B Wellsite Calibration - HRLT M12</b>							
Before: 19-Jun-2014 0:19    After: 19-Jun-2014 1:30							
HRLT M1-M2 Voltage Plus - 0	0	N/A	1755	1754	-1.774	53.42	UV
HRLT M1-M2 Voltage Plus - 1	0	N/A	1834	1839	4.443	53.42	UV
HRLT M1-M2 Voltage Plus - 2	0	N/A	1837	1836	-0.5760	53.42	UV
HRLT M1-M2 Voltage Plus - 3	0	N/A	1855	1855	-0.2561	53.42	UV
HRLT M1-M2 Voltage Plus - 4	0	N/A	1790	1788	-1.754	53.42	UV
HRLT M1-M2 Voltage Plus - 5	0	N/A	1769	1767	-1.449	53.42	UV
HRLT M1-M2 Voltage Plus - 6	0	N/A	-1790	-1797	-6.974	53.42	UV
HRLT M1-M2 Voltage Plus - 7	0	N/A	1781	1781	0	53.42	UV
<b>High Resolution Laterolog Array - B Wellsite Calibration - HRLT M23</b>							
Before: 19-Jun-2014 0:19    After: 19-Jun-2014 1:30							
HRLT M2-M3 Voltage Plus - 0	0	N/A	1741	1739	-1.698	53.42	UV
HRLT M2-M3 Voltage Plus - 1	0	N/A	1832	1836	4.380	53.42	UV
HRLT M2-M3 Voltage Plus - 2	0	N/A	1836	1835	-0.6879	53.42	UV
HRLT M2-M3 Voltage Plus - 3	0	N/A	1857	1857	-0.2483	53.42	UV
HRLT M2-M3 Voltage Plus - 4	0	N/A	1786	1784	-1.740	53.42	UV
HRLT M2-M3 Voltage Plus - 5	0	N/A	1766	1764	-1.340	53.42	UV
HRLT M2-M3 Voltage Plus - 6	0	N/A	-1777	-1783	-6.704	53.42	UV
HRLT M2-M3 Voltage Plus - 7	0	N/A	1781	1781	0	53.42	UV
<b>High Resolution Laterolog Array - B Wellsite Calibration - HRLT V34</b>							
Before: 19-Jun-2014 0:19    After: 19-Jun-2014 1:30							
HRLT A3-A4 Voltage Plus - 0	0	N/A	68450	68400	-53.31	2100	UV
HRLT A3-A4 Voltage Plus - 1	0	N/A	71820	72020	197.5	2100	UV

HRLT A3-A4 Voltage Plus - 2	0	N/A	72280	72270	-12.32	2100	UV
HRLT A3-A4 Voltage Plus - 3	0	N/A	73380	73380	1.516	2100	UV
HRLT A3-A4 Voltage Plus - 4	0	N/A	70540	70490	-55.48	2100	UV
HRLT A3-A4 Voltage Plus - 5	0	N/A	69750	69700	-48.54	2100	UV
HRLT A3-A4 Voltage Plus - 6	0	N/A	-68660	-68960	-293.0	2100	UV
HRLT A3-A4 Voltage Plus - 7	0	N/A	70000	70000	0	2100	UV

High Resolution Laterolog Array - B Wellsite Calibration - HRLT V45

Before: 19-Jun-2014 0:19 After: 19-Jun-2014 1:30

HRLT A4-A5 Voltage Plus - 0	0	N/A	68730	68680	-51.44	2100	UV
HRLT A4-A5 Voltage Plus - 1	0	N/A	72220	72390	169.2	2100	UV
HRLT A4-A5 Voltage Plus - 2	0	N/A	72650	72630	-12.33	2100	UV
HRLT A4-A5 Voltage Plus - 3	0	N/A	73720	73720	1.516	2100	UV
HRLT A4-A5 Voltage Plus - 4	0	N/A	70840	70780	-61.51	2100	UV
HRLT A4-A5 Voltage Plus - 5	0	N/A	70030	69990	-34.95	2100	UV
HRLT A4-A5 Voltage Plus - 6	0	N/A	-69040	-69320	-274.8	2100	UV
HRLT A4-A5 Voltage Plus - 7	0	N/A	70000	70000	0	2100	UV

High Resolution Laterolog Array - B Wellsite Calibration - HRLT V56

Before: 19-Jun-2014 0:19 After: 19-Jun-2014 1:30

HRLT A5-A6 Voltage Plus - 0	0	N/A	68640	68590	-50.18	2100	UV
HRLT A5-A6 Voltage Plus - 1	0	N/A	71940	72110	172.8	2100	UV
HRLT A5-A6 Voltage Plus - 2	0	N/A	72400	72400	-2.461	2100	UV
HRLT A5-A6 Voltage Plus - 3	0	N/A	73540	73540	6.836	2100	UV
HRLT A5-A6 Voltage Plus - 4	0	N/A	70690	70640	-50.13	2100	UV
HRLT A5-A6 Voltage Plus - 5	0	N/A	69910	69890	-27.83	2100	UV
HRLT A5-A6 Voltage Plus - 6	0	N/A	-68780	-69040	-260.9	2100	UV
HRLT A5-A6 Voltage Plus - 7	0	N/A	70000	70000	0	2100	UV

High Resolution Laterolog Array - B Wellsite Calibration - HRLT VTP

Before: 19-Jun-2014 0:19 After: 19-Jun-2014 1:30

HRLT Torpedo-M0 Voltage - 0	0	N/A	-68320	-68250	62.30	2100	UV
HRLT Torpedo-M0 Voltage - 1	0	N/A	-72260	-72460	-202.5	2100	UV
HRLT Torpedo-M0 Voltage - 2	0	N/A	-72700	-72680	21.90	2100	UV
HRLT Torpedo-M0 Voltage - 3	0	N/A	-73820	-73830	-10.85	2100	UV
HRLT Torpedo-M0 Voltage - 4	0	N/A	-70890	-70840	49.79	2100	UV
HRLT Torpedo-M0 Voltage - 5	0	N/A	-70070	-70030	33.38	2100	UV
HRLT Torpedo-M0 Voltage - 6	0	N/A	69040	69330	289.4	2100	UV
HRLT Torpedo-M0 Voltage - 7	0	N/A	-70000	-70000	0	2100	UV

High Resolution Laterolog Array - B Wellsite Calibration - HRLT VBD

Before: 19-Jun-2014 0:19 After: 19-Jun-2014 1:30

HRLT Bridle#9-M0 Voltage - 0	0	N/A	-68300	-68250	55.71	2100	UV
HRLT Bridle#9-M0 Voltage - 1	0	N/A	-72250	-72430	-182.6	2100	UV
HRLT Bridle#9-M0 Voltage - 2	0	N/A	-72680	-72670	7.820	2100	UV
HRLT Bridle#9-M0 Voltage - 3	0	N/A	-73800	-73810	-16.64	2100	UV
HRLT Bridle#9-M0 Voltage - 4	0	N/A	-70890	-70830	62.55	2100	UV
HRLT Bridle#9-M0 Voltage - 5	0	N/A	-70070	-70030	42.65	2100	UV
HRLT Bridle#9-M0 Voltage - 6	0	N/A	69020	69310	290.3	2100	UV
HRLT Bridle#9-M0 Voltage - 7	0	N/A	-70000	-70000	0	2100	UV

High Resolution Laterolog Array - B Wellsite Calibration - HRLT ISO

Before: 19-Jun-2014 0:19 After: 19-Jun-2014 1:30

HRLT Source Current Plus - 0	0	N/A	284.9	284.7	-0.2205	8.520	UA
HRLT Source Current Plus - 1	0	N/A	281.1	281.1	0	8.520	UA
HRLT Source Current Plus - 2	0	N/A	281.1	281.1	0	8.520	UA
HRLT Source Current Plus - 3	0	N/A	281.1	281.1	0	8.520	UA
HRLT Source Current Plus - 4	0	N/A	281.1	281.1	0	8.520	UA
HRLT Source Current Plus - 5	0	N/A	281.1	281.1	0	8.520	UA
HRLT Source Current Plus - 6	0	N/A	281.1	281.1	0	8.520	UA
HRLT Source Current Plus - 7	0	N/A	281.1	281.1	0	8.520	UA

High Resolution Laterolog Array - B Wellsite Calibration - HRLT MV

Before: 19-Jun-2014 0:19 After: 19-Jun-2014 1:30

HRLT Vertical Voltage PI - 0	0	N/A	-321.6	-321.4	0.2695	9.681	UV
HRLT Vertical Voltage PI - 1	0	N/A	-328.0	-328.8	-0.8510	9.681	UV
HRLT Vertical Voltage PI - 2	0	N/A	-328.4	-328.4	-0.008118	9.681	UV
HRLT Vertical Voltage PI - 3	0	N/A	-330.0	-330.1	-0.05759	9.681	UV
HRLT Vertical Voltage PI - 4	0	N/A	-315.6	-315.4	0.2337	9.681	UV
HRLT Vertical Voltage PI - 5	0	N/A	-326.7	-326.6	0.1897	9.681	UV
HRLT Vertical Voltage PI - 6	0	N/A	331.4	332.8	1.429	9.681	UV
HRLT Vertical Voltage PI - 7	0	N/A	-322.7	-322.7	0	9.681	UV

Hostile Litho-Density Sonde Wellsite Calibration - Background Measurement

Master: 18-May-2014 19:49 Before: 10-Jun-2014 22:19 After: 18-May-2014 20:19

SS Cs Resolution Bkg	9.000	7.743	7.746	7.752	0.006506	1.800	%
LS Cs Resolution Bkg	9.000	7.999	7.986	8.037	0.05058	1.800	%
LSW1 Background	100.0	83.92	82.67	83.69	1.024	0.03000	CPS
LSW2 Background	100.0	76.32	75.63	74.78	-0.8435	0.03000	CPS
LSW3 Background	200.0	172.1	170.5	171.0	0.4849	0.03000	CPS
LSW4 Background	250.0	210.7	209.5	210.5	0.9934	0.03000	CPS

LSW5 Background	600.0	492.1	491.9	491.6	-0.3414	0.03000	CPS
SSW1 Background	100.0	81.53	81.07	81.08	0.007065	0.03000	CPS
SSW2 Background	200.0	139.8	139.2	138.5	-0.7151	0.03000	CPS
SSW3 Background	500.0	387.8	389.7	387.3	-2.356	0.03000	CPS
SSW4 Background	270.0	206.4	210.7	209.5	-1.239	0.03000	CPS
SSW5 Background	200.0	147.8	147.6	149.0	1.473	0.03000	CPS

Hostile Litho-Density Sonde Wellsite Calibration - Aluminum Measurement

Master: 18-May-2014 19:49

LSW1 Aluminum	600.0	538.3	N/A	N/A	N/A	N/A	CPS
LSW2 Aluminum	900.0	769.4	N/A	N/A	N/A	N/A	CPS
LSW3 Aluminum	1100	928.6	N/A	N/A	N/A	N/A	CPS
LSW4 Aluminum	580.0	465.6	N/A	N/A	N/A	N/A	CPS
LSW5 Aluminum	570.0	422.0	N/A	N/A	N/A	N/A	CPS
SSW1 Aluminum	2800	2327	N/A	N/A	N/A	N/A	CPS
SSW2 Aluminum	8000	6377	N/A	N/A	N/A	N/A	CPS
SSW3 Aluminum	11600	8919	N/A	N/A	N/A	N/A	CPS
SSW4 Aluminum	5000	3682	N/A	N/A	N/A	N/A	CPS
SSW5 Aluminum	660.0	438.9	N/A	N/A	N/A	N/A	CPS

Hostile Litho-Density Sonde Wellsite Calibration - Lithology Measurement

Master: 18-May-2014 19:49

LSW1 Iron	400.0	356.8	N/A	N/A	N/A	N/A	CPS
LSW2 Iron	730.0	604.7	N/A	N/A	N/A	N/A	CPS
LSW3 Iron	1000	798.2	N/A	N/A	N/A	N/A	CPS
LSW4 Iron	520.0	413.6	N/A	N/A	N/A	N/A	CPS
LSW5 Iron	470.0	384.1	N/A	N/A	N/A	N/A	CPS
SSW1 Iron	2100	1682	N/A	N/A	N/A	N/A	CPS
SSW2 Iron	6800	5273	N/A	N/A	N/A	N/A	CPS
SSW3 Iron	10800	8065	N/A	N/A	N/A	N/A	CPS
SSW4 Iron	4600	3345	N/A	N/A	N/A	N/A	CPS
SSW5 Iron	580.0	385.6	N/A	N/A	N/A	N/A	CPS

Hostile Litho-Density Sonde Wellsite Calibration - Caliper Calibration

Before: 11-Jun-2014 0:30

HLDS Caliper Small Ring	12.00	N/A	14.74	N/A	N/A	N/A	IN
HLDS Caliper Large Ring	15.19	N/A	18.18	N/A	N/A	N/A	IN

Accelerator-Porosity Tool Wellsite Calibration - Detector Background

Master: 17-May-2014 21:32 Before: 10-Jun-2014 22:24 After: 19-Jun-2014 2:01

Near Det Bkg Cntrate	30.00	25.77	26.26	26.29	0.02178	N/A	CPS
Far Det Bkg Cntrate	30.00	26.80	27.58	27.98	0.4043	N/A	CPS
Array-1 Det Bkg Cntrate	30.00	25.44	26.75	25.90	-0.8481	N/A	CPS
Array-2 Det Bkg Cntrate	30.00	26.70	27.56	27.66	0.1053	N/A	CPS
Array Therm Det Bkg Cntrate	30.00	27.35	24.63	26.50	1.863	N/A	CPS

Accelerator-Porosity Tool Wellsite Calibration - Calibration Ratios

Master: 17-May-2014 21:51

Near/Far Calibration Ratio	0.9250	0.9766	N/A	N/A	N/A	N/A	
Near/Array Calibration Ratio	1.030	1.084	N/A	N/A	N/A	N/A	
Near/Array Cal Ratio Up/Down	1.000	1.013	N/A	N/A	N/A	N/A	

Accelerator-Porosity Tool Wellsite Calibration - Tank Check

Master: 17-May-2014 21:51

Array-1 Standoff Porosity	11.75	10.40	N/A	N/A	N/A	N/A	PU
Array-2 Standoff Porosity	11.75	10.48	N/A	N/A	N/A	N/A	PU
Average Slowing Down Time	6.000	6.060	N/A	N/A	N/A	N/A	US
Array-1 SDT Ratio Up/Down	1.000	0.9751	N/A	N/A	N/A	N/A	
Array-2 SDT Ratio Up/Down	1.000	0.9750	N/A	N/A	N/A	N/A	
Sigma Formation	27.50	34.86	N/A	N/A	N/A	N/A	CU

Accelerator-Porosity Tool Wellsite Calibration - CCR7 signal boxes

Master: 17-May-2014 20:53

Near Detector Plateau Setting	1650	1697	N/A	N/A	N/A	N/A	V
Far Detector Plateau Setting	2000	2030	N/A	N/A	N/A	N/A	V
Array Detector Plateau Setting	2000	1940	N/A	N/A	N/A	N/A	V

Hostile Natural Gamma Ray Sonde Wellsite Calibration - Detector 1 Check

Master: 17-May-2014 3:32 Before: 10-Jun-2014 22:38 After: 17-May-2014 3:46

Na 511 Peak Loc	40.00	39.68	39.69	39.70	0.003128	1.000	
Na 511 Peak Res	15.50	14.95	15.43	16.14	0.7069	2.000	%
High Voltage	1150	1174	1175	1174	-0.08655	N/A	V
Na 1785 Peak Loc	142.6	143.3	141.3	142.5	1.252	7.000	
Na 1785 Peak Res	8.500	7.428	7.650	8.638	0.9881	2.000	%
Temperature	15.50	29.15	30.00	29.26	-0.7430	N/A	DEGC
Na Count Rate	45.00	12.49	11.75	11.88	0.1340	8.000	CPS

Hostile Natural Gamma Ray Sonde Wellsite Calibration - Detector 2 Check

Master: 17-May-2014 3:32 Before: 10-Jun-2014 22:38 After: 17-May-2014 3:46

Na 511 Peak Loc	40.00	39.32	39.63	39.58	-0.04301	1.000	
Na 511 Peak Res	15.50	16.57	16.61	16.31	-0.2982	2.000	%
High Voltage	1150	1107	1110	1108	-1.606	N/A	V

High Voltage	115.0	115.7	115.0	115.0	-1.000	N/A	V
Na 1785 Peak Loc	142.6	140.5	142.7	142.7	-0.004791	7.000	%
Na 1785 Peak Res	8.500	9.002	9.484	9.819	0.3349	2.000	%
Temperature	15.50	29.28	30.44	29.38	-1.062	N/A	DEGC
Na Count Rate	45.00	12.67	12.05	12.14	0.09100	8.000	CPS

Hostile Natural Gamma Ray Sonde Wellsite Calibration – Ratio Of Detector 1 To Detector 2

Master: 17-May-2014 3:32 Before: 10-Jun-2014 22:38 After: 17-May-2014 3:46

Coincidence Count Rate Ratio	1.000	0.9880	0.9769	0.9796	0.002670	0.05000
------------------------------	-------	--------	--------	--------	----------	---------

Hostile Natural Gamma Ray Sonde Master Calibration – Detector 1 Calibration

Master: 17-May-2014 3:27

Na 511 Peak Set Point	40.00	41.00	--	--	--	--	
Th Peak Loc	209.6	210.1	--	--	--	--	
Th Peak Res	7.000	6.596	--	--	--	--	%
Background Count Rate	142.5	20.48	--	--	--	--	CPS
Gain Ratio	1.000	1.007	--	--	--	--	

Hostile Natural Gamma Ray Sonde Master Calibration – Detector 2 Calibration

Master: 17-May-2014 3:27

Na 511 Peak Set Point	40.00	41.00	--	--	--	--	
Th Peak Loc	209.6	207.6	--	--	--	--	
Th Peak Res	7.000	7.200	--	--	--	--	%
Background Count Rate	142.5	21.26	--	--	--	--	CPS
Gain Ratio	1.000	1.004	--	--	--	--	

Enhanced DTS Cartridge Wellsite Calibration – EDTC Accelerometer Calibration

Before: Calibration out of date 18-Jun-2014 19:30

EDTC Z-Axis Acceleration	9.810	N/A	9.720	N/A	N/A	N/A	M/S2
--------------------------	-------	-----	-------	-----	-----	-----	------

Enhanced DTS Cartridge Wellsite Calibration – Detector Calibration

Before: Calibration out of date 17-May-2014 3:36 After: Calibration out of date 17-May-2014 3:43

Gamma Ray (Jig – Bkg)	157.1	N/A	157.1	153.5	-3.532	14.28	GAPI
Gamma Ray (Calibrated)	165.0	N/A	165.0	161.3	-3.710	15.00	GAPI

Accelerator-Porosity Tool – Detector Plateau Settings :

Near Detector Plateau Setting	1697 V
Far Detector Plateau Setting	2030 V
Array Detector Plateau Setting	1940 V

High Resolution Laterolog Array – B / Equipment Identification

Primary Equipment:		
HRLT Sonde	HRLS – B	768
Auxiliary Equipment:		
HRLT lower Housing	HRLH – B	968
HRLT Lower Cartridge	HRLC – B	974
HRLT upper Housing	HRUH – B	978
HRLT Upper Cartridge	HRUC – B	764

Hostile Litho-Density Sonde / Equipment Identification

Primary Equipment:		
Hostile Litho Density Sonde	HLDS – D	35
Hostile Litho Density High Voltage	HLDV – D	35
Gamma Source Radioactive	GSR – Z	8113
Auxiliary Equipment:		
Hostile Litho Density Pad	HLDP – C	35
Hostile Litho Density High Voltage Housi	HEH – H	35

Litho-Density Spectroscopy Cartridge – B / Equipment Identification

Primary Equipment:		
LDSC Cartridge	LDSC – B	326
Auxiliary Equipment:		
LDSC Housing	LDSH – A	303



Accelerator-Porosity Tool / Equipment Identification

Primary Equipment:

Accelerator-Porosity Sonde	APS - C	212
APS Minitron	MNTR - F	6504

Auxiliary Equipment:

Accelerator-Porosity Housing	APH - AC	121
APS Calibration Water Tank	SFT - 178	1
APS Aluminum Calibrator Sleeve	SFT - 281	1

Hostile Natural Gamma Ray Cartridge - B / Equipment Identification

Primary Equipment:

HNGC Cartridge	HNGC - B	300
----------------	----------	-----

Auxiliary Equipment:

HNGC Housing	HNGH - A	115
--------------	----------	-----

Hostile Natural Gamma Ray Sonde / Equipment Identification

Primary Equipment:

HNGS Sonde	HNGS - BA	194
------------	-----------	-----

Auxiliary Equipment:

HNGS Sonde Housing	HNSH - BA	205
Gamma Source Radioactive	GSR - U	616008

Hostile Natural Gamma Ray Sonde Wellsite Calibration

Detector 1 Check

Phase	Na 511 Peak Loc	Value	Phase	Na 511 Peak Res %	Value	Phase	High Voltage V	Value
Master		39.68	Master		14.95	Master		1174
Before		39.69	Before		15.43	Before		1175
After		39.70	After		16.14	After		1174
	37.50 (Minimum) 40.00 (Nominal) 43.50 (Maximum)			12.00 (Minimum) 15.50 (Nominal) 19.00 (Maximum)			900.0 (Minimum) 1150 (Nominal) 1600 (Maximum)	
Phase	Na 1785 Peak Loc	Value	Phase	Na 1785 Peak Res %	Value	Phase	Temperature DEGC	Value
Master		143.3	Master		7.428	Master		29.15
Before		141.3	Before		7.650	Before		30.00
After		142.5	After		8.638	After		29.26
	135.0 (Minimum) 142.6 (Nominal) 150.3 (Maximum)			7.000 (Minimum) 8.500 (Nominal) 11.00 (Maximum)			-28.89 (Minimum) 15.50 (Nominal) 60.00 (Maximum)	
Phase	Na Count Rate CPS	Value						
Master		12.49						
Before		11.75						
After		11.88						
	10.00 (Minimum) 45.00 (Nominal) 100.0 (Maximum)							
Master: 17-May-2014 3:32			Before: 10-Jun-2014 22:38			After: 17-May-2014 3:46		





Hostile Natural Gamma Ray Sonde Wellsite Calibration

Detector 2 Check

Phase	Na 511 Peak Loc	Value	Phase	Na 511 Peak Res %	Value	Phase	High Voltage V	Value
Master		39.32	Master		16.57	Master		1107
Before		39.63	Before		16.61	Before		1110
After		39.58	After		16.31	After		1108
	37.50 (Minimum) 40.00 (Nominal) 43.50 (Maximum)			12.00 (Minimum) 15.50 (Nominal) 19.00 (Maximum)			900.0 (Minimum) 1150 (Nominal) 1600 (Maximum)	

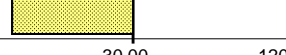

Before		9.720
	9.610 (Minimum)      9.810 (Nominal)      10.01 (Maximum)	
Before: 18-Jun-2014 19:30		

Enhanced DTS Cartridge Wellsite Calibration								
Detector Calibration								
Phase	Gamma Ray Background GAPI	Value	Phase	Gamma Ray (Jig - Bkg) GAPI	Value	Phase	Gamma Ray (Calibrated) GAPI	Value
Before		6.621	Before		157.1	Before		165.0
After		6.812	After		153.5	After		161.3
	0 (Minimum)      30.00 (Nominal)      120.0 (Maximum)			142.8 (Minimum)      157.1 (Nominal)      171.3 (Maximum)			150.0 (Minimum)      165.0 (Nominal)      180.0 (Maximum)	
Before: 17-May-2014 3:36			After: 17-May-2014 3:43					

Company: **Lamont Doherty Earth Observatory**

**Schlumberger**

Well: **Expedition 351, Site U1438D**

Field: **IBM Arc Origins**

Rig: **JOIDES Resolution**

Ocean: **Pacific**

Hostile Natural Gamma Sonde (HNGS)  
Spectroscopy Log